

Dome Heat Shrinkable Seal Fiber Optic Splice Closure (FOSC)

TK-SC-V07-2

Installation Manual



1. Scope of application

This Installation Manual suits for the Fiber Optic Splice Closure (Hereafter abbreviated as FOSC), as the guidance of proper installation.

The scope of application is: aerial, underground, wall-mounting, duct-mounting and handhole- mounting. The ambient temperature ranges from -40°C to $+65^{\circ}\text{C}$.

2. Basic structure and configuration

2.1 Dimension and capacity

| | |
|---------------------------------------|---|
| Outside dimension (Height x Diameter) | 288mm×178mm |
| Weight (excluding outside box) | 1550 g— 1740g |
| Number of inlet/out ports | 5 pieces in general |
| Diameter of fiber cable | $\Phi 8\text{mm} \sim \Phi 20 \text{ mm}$ |
| Capacity of FOSC | Bunchy: 4-48 (cores) |

2.2 Main components

| No. | Name of components | Quantity | Usage | Remarks |
|-----|--------------------------------|-----------------------|---|---|
| 1 | FOSC cover | 1 piece | Protecting fiber cable splices in whole | Height x Diameter 208mm x 132mm |
| 2 | Fiber optic splice tray (FOST) | Max. 4 trays (bunchy) | Fixing heat shrinkable protective sleeve and holding fibers | Suitable for: Bunchy:4,6,8,12(cores) |
| 3 | Fiber holding tray | 1 pcs | Holding fibers with protective coat | |
| 4 | Base | 1set | Fixing internal and external structure | |
| 5 | Plastic hoop | 1 set | Fixing between FOSC cover and base | |
| 6 | Seal fitting | 1 piece | Sealing between FOSC cover and base | |
| 7 | Pressure testing valve | 1 set | After inject air, it is used for pressure testing and sealing testing | Configuration as per requirement |
| 8 | Earthing deriving device | 1 set | Deriving metal parts of fiber cables in FOSC for earthing connection | Configuration as per requirement |

2.3 Main accessories and special tools

| No. | Name of accessories | Quantity | Usage | Remarks |
|-----|--|----------------------|--|----------------------------------|
| 1 | Heat shrinkable protective sleeve | | Protecting fiber splices | Configuration as per capacity |
| 2 | Nylon tie | | Fixing fiber with protective coat | Configuration as per capacity |
| 3 | Heat shrinkable fixing sleeve (single) | | Fixing and sealing single fiber cable | Configuration as per requirement |
| 4 | Heat shrinkable fixing sleeve (mass) | | Fixing and sealing mass of fiber cable | Configuration as per requirement |
| 5 | Branching clip | | Branching fiber cables | Configuration as per requirement |
| 6 | Earthing wire | 1 piece | Putting through between earthing devices | |
| 7 | Desiccant | 1 bag | Put into FOSC before sealing for desiccating air | |
| 8 | Labeling paper | 1 piece | Labeling fibers | |
| 9 | Special wrench | 1 piece | Tightening nut of reinforced core | |
| 10 | Metal hoop | 1 set | For wall mounting and pole hugging | |
| 11 | Buffer tube | decided by customers | Hitched to fibers and fixed with FOST, managing buffer. | Configuration as per requirement |
| 12 | Aluminum foil paper | 1 pc | Protect the bottom of Fiber Optic Splice Closure and cable inlet/outlet tubes when heat the heat shrinkable sleeves. | |

3. Necessary tools for installation

3.1 Supplementary materials (to be provided by operator)

| Name of materials | Usage |
|-------------------|------------------------------|
| Scotch tape | Labeling, temporarily fixing |
| Ethyl alcohol | Cleaning |
| Gauze | Cleaning |

3.2 Special tools (to be provided by operator)

| Name of tools | Usage |
|----------------|--|
| Fiber cutter | Cutting off fiber cable |
| Fiber stripper | Strip off protective coat of fiber cable |
| Combo tools | Assembling FOSC |

3.3 Universal tools(to be provided by operator)

| Name of tools | Usage and specification |
|--------------------|---|
| Band tape | Measuring fiber cable |
| Pipe cutter | Cutting fiber cable |
| Electrical cutter | Take off protective coat of fiber cable |
| Combination pliers | Cutting off reinforced core |
| Screwdriver | Crossing/Paralleling screwdriver |
| Scissor | |
| Waterproof cover | Waterproof, dustproof |
| Metal wrench | Tightening nut of reinforced core |

3.4 Splicing and testing instruments (to be provided by operator)

| Name of instruments | Usage and specification |
|----------------------------|---------------------------------------|
| Fusion Splicing Machine | Fiber splicing |
| OT DR | Splicing testing |
| Provisional splicing tools | Provisional testing |
| Fire sprayer | Sealing heat shrinkable fixing sleeve |

Notice: The above-mentioned tools and testing instruments should be provided by the operators themselves.

4. Installation flow chart

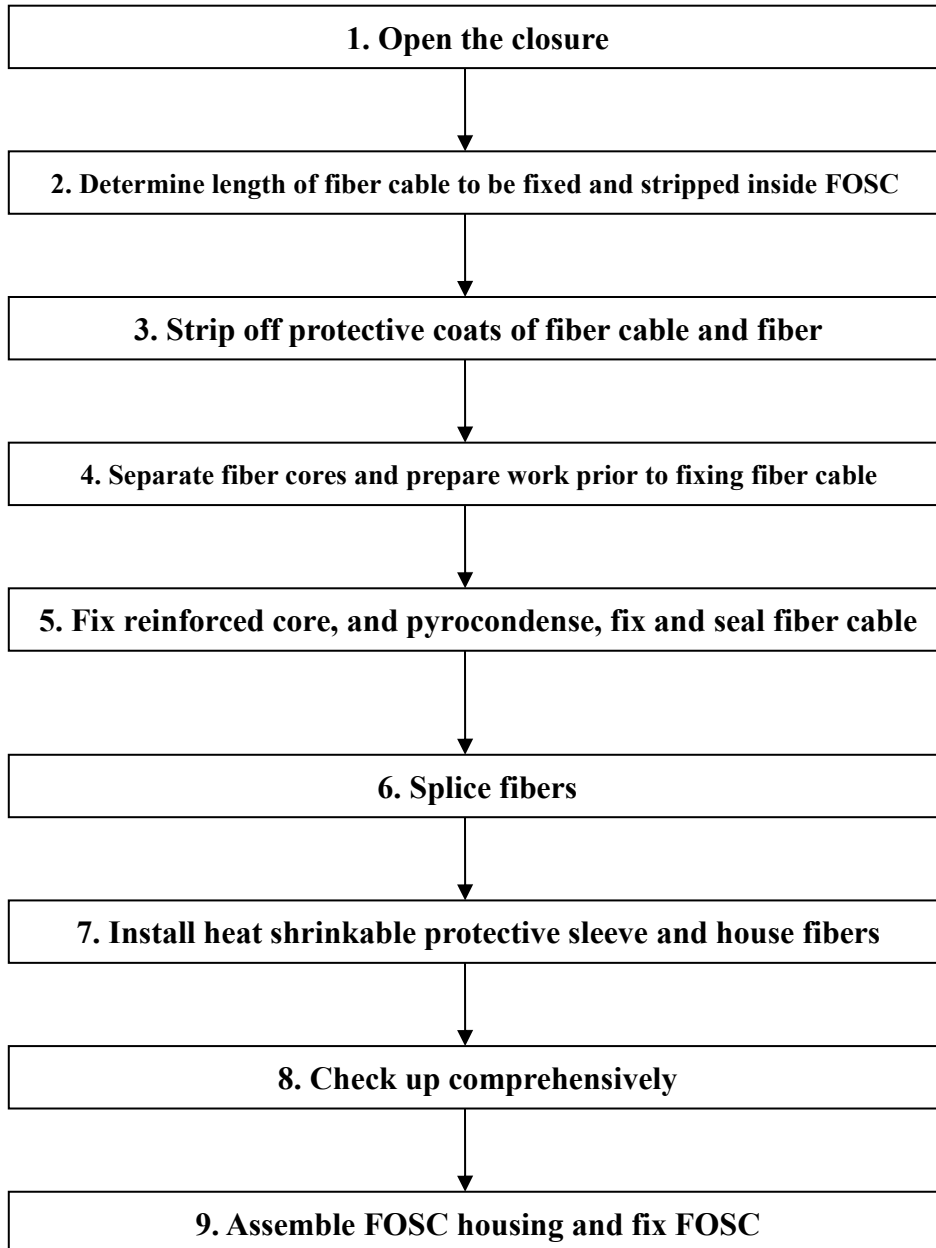

5. The process of installing FOSC.

5.1 Step One - Open the closure

- 5.1.1 Cleaning the locale and determine where to install the FOSC and then place fiber cables required.
- 5.1.2 Check whether the main components and accessories have been well prepared

inside the package.

5.1.3 Open the closure

- ① Demount hoop fixing bolt and pull hoop locking system out, then proceed in demounting the hoop.
- ② Pull the FOSC cover upwards out, installation could begin.

5.1.4 See Drawing 1

Important issues: If the weather condition is not good enough, then a tent must be pitched for waterproof and dustproof.

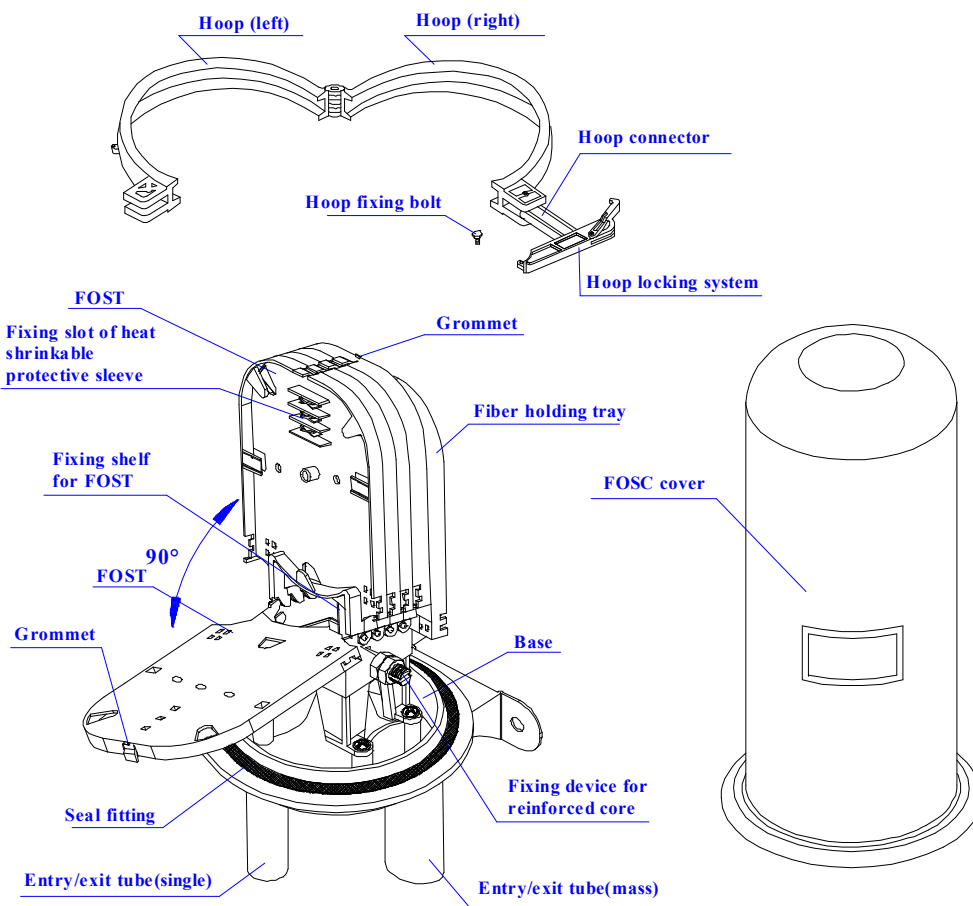

Drawing 1

5.2 Step Two -Determine length of fiber cable to be fixed and stripped inside FOSC

5.2.1 If all fibers are for branch splicing, please refer to Drawing 2(A) for stripping length.

5.2.2 If some fibers are for straight-through, while others are for branch splicing, please refer to Drawing 2(B) for stripping length.

5.2.3 See Drawing 2.

- Important issues:**
1. Reserve enough length of fiber cable to be spliced.
 2. Stripping length also could be decided by customers according to installation requirement

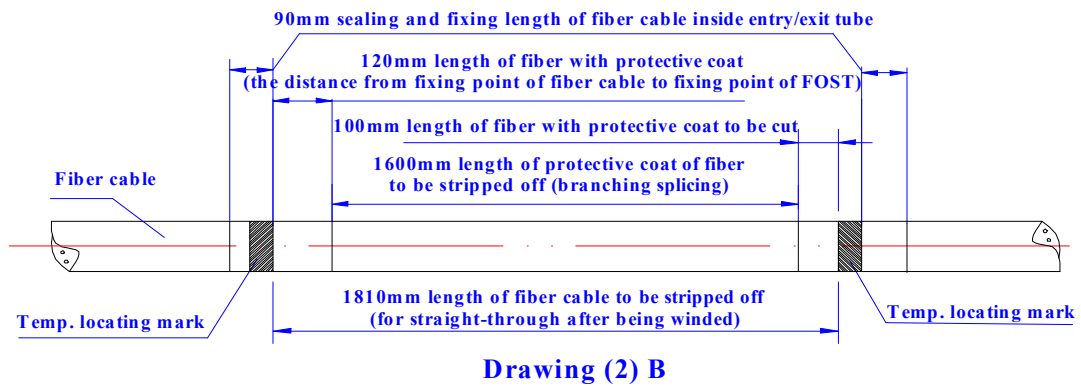
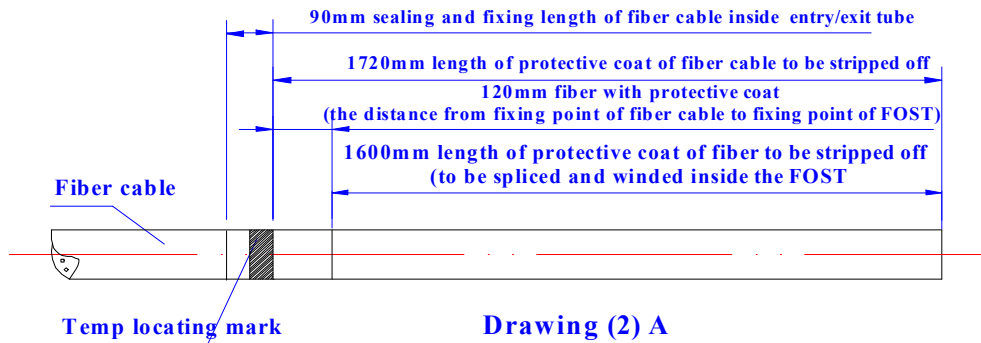

5.3 Step Three –Strip off protective coat of fiber cable and fiber

5.3.1 Strip off protective coat of fiber cable from the temp. locating mark with the cutter and the stripper, please refer to Drawing 2 for stripping length. Stripping length also could be decided according to installation requirement

5.3.2 See Drawing 3.

Important issues: If it is difficult to pull all the protective coat of fiber cable at one time, strip it off section by section to avoid fiber breakage.

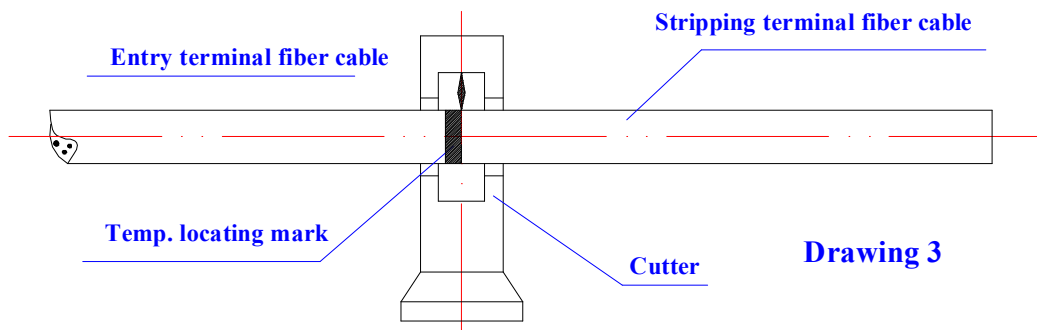

5.4 Step Four – Separate fiber cores and prepare work prior to fixing fiber cable.

5.4.1 Wind 2 layers of insulation tape on protective coat of fiber core for protection.

Meanwhile, get rid of the stuffing to separate fiber core and clean them. Form a ring with the diameter of 100mm or so and fix it on the fiber temporarily by adhesive tape.

5.4.2 Depending on fiber cable stripped, the following two cases are available.

- ① All fibers are to be branched after being spliced completely.

② Some of fibers are for straight-through after being winded, while the others are for branch splicing.

5.4.3 The FOSC is provided with 3 single entry/exit tubes which suit for single fiber cables with max. diameter $\phi 20\text{mm}$ and 1 mass entry/exit tube which suits for 1 piece of fiber cable with max. diameter $\phi 20\text{mm}$ or 2 pieces of fiber cables with max. diameter $\phi 15\text{mm}$ or multi-pieces of fiber cables with short diameter.

5.4.4 Mass entry/exit tube is required if some fibers are for straight-through

5.4.5 The corresponding entry/exit tube cover could be slightly knocked out with screwdriver from inside to outside according to number and diameter of fiber cable required.

5.4.6 Reserve reinforced core in 70mm length and cut off the unnecessary ones.

5.4.7 See Drawing 4 and Drawing 5.

Important Issues: Entry/exit tubes are to be selected accurately to make it easy for splicing and sealing.

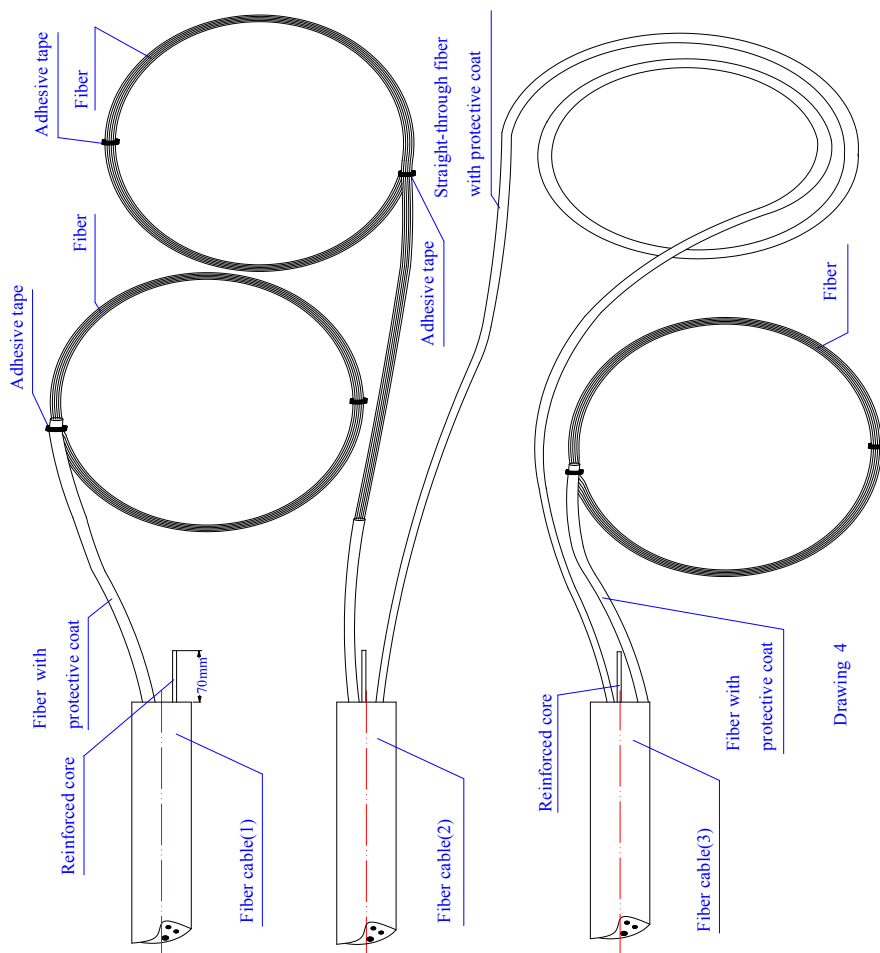

5.5 Fixation of reinforced core, and pyrocondensation, fixation & sealing of fiber cable.

5.5.1 Insert fiber cable into the corresponding heat shrinkable fixing tube, further insert them into entry/exit tube at the bottom of FOSC.

5.5.2 Demount fixing nut of reinforced core with a special wrench (plastic one), which is to be inserted

into the fixing slot afterward and tighten it. Then retighten it with a metal wrench (the metal wrench is to be provided by operator).

5.5.3 Hitch heat shrinkable fixing sleeve to the fiber cable till its root by hand.

5.5.4 Please refer to Drawing 5 for installing branching clip.

5.5.5 Heat shrinkable fixing sleeve with fire sprayer to make it hugging entry/exit tube and fiber cable to reach complete sealing.

5.5.6 See Drawing 5

important issue: 1. Fixing nut of reinforced core should be tightened.

2. While heating, heat shrinkable fixing tube should shrink evenly, and there should be no bubbles, pores and other defects inside the tube.

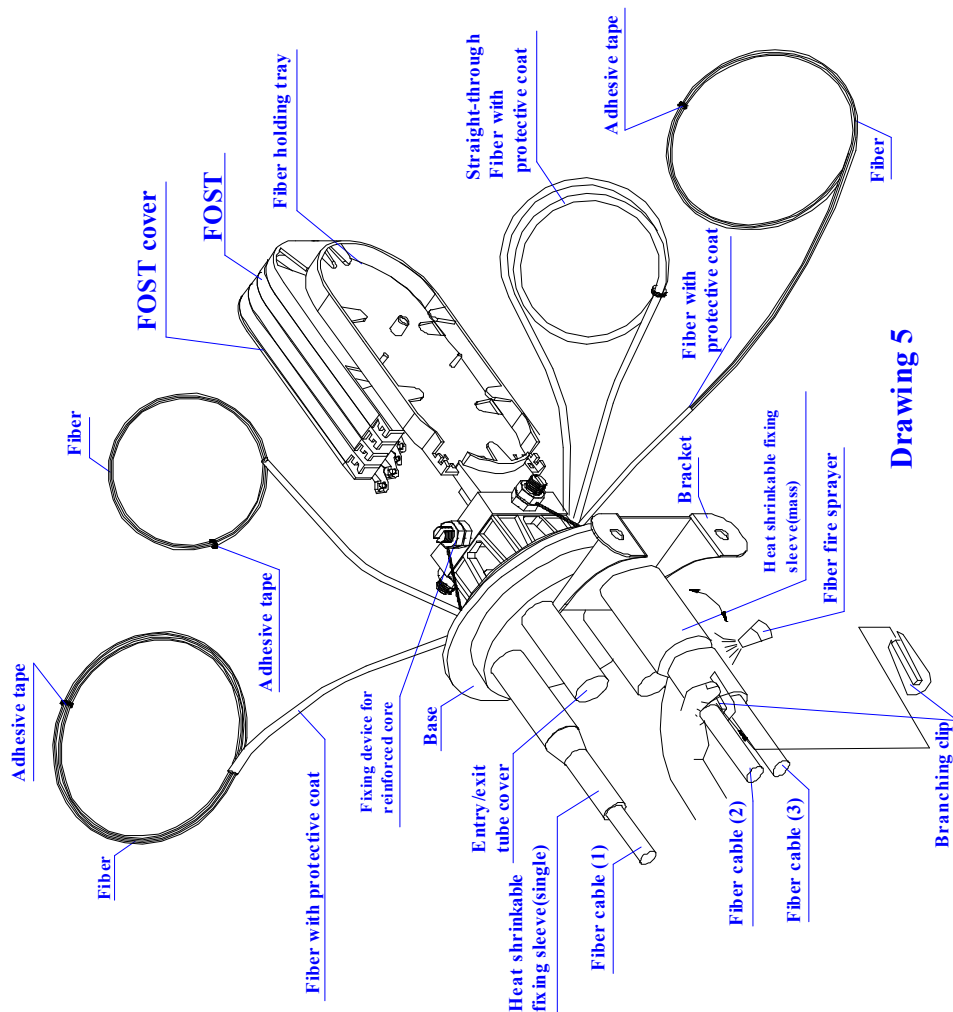

5.6 Step Six - Splice fibers

5.6.1 Follow user manual of fusion splicing machine to splice fiber.

Important issue: pay attention to the twist and bend of fiber

5.7 Step Seven -Install heat shrinkable protective sleeve and house fibers.

5.7.1 When having completed splicing the fibers, the first fiber ring should be housed on the farthest side of FOST, the remaining fiber optic should be winded, forming a ring with diameter not less than 80mm. then put it into FOST (Fiber Optic Splice Tray) together with heat shrinkable protective sleeve.

(Firstly fix heat shrinkable protective sleeve into the slot, then enlarge the diameter of fiber ring properly.)

5.7.2 see Drawing 6

Important issue: pay attention to the twist and bend of fiber.

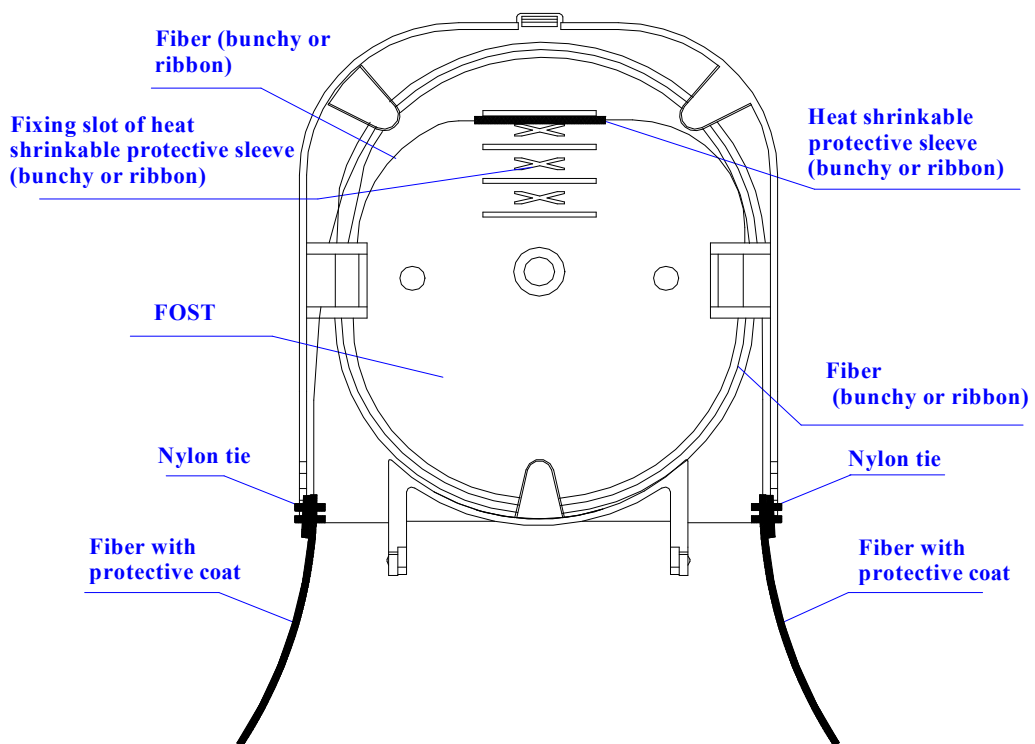

Drawing 6

5.8 Step Eight - Check up comprehensively

To ensure the technical requirements, the following instructions must be followed:

- 5.8.1 Fibers with protective coat are fixed with nylon tie at the entrance of FOST.
- 5.8.2 Grommet should be pressed from inside to outside in order to properly install FOST.
- 5.8.3 Straight-through and reserved fibers with protective coat should be winded to the fiber holding tray.
- 5.8.4 Check whether the internal tighteners and fixing nut of reinforced core are well tightened.
- 5.8.5 Check whether seal fitting is installed neatly and smoothly.
- 5.8.6 Check whether heat shrinkable fixing sleeve is reliable and sealing completely.

5.8.7 See Drawing 7.

Important issues: If any problems occur, they should be solved right away.

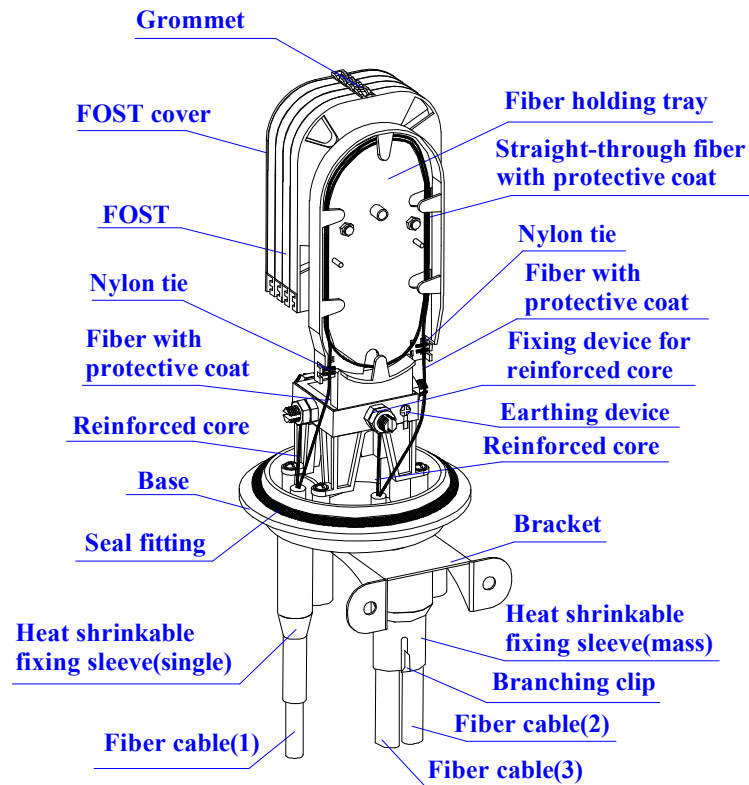

Drawing 7

5.9 Step Nine – Assemble FOSC housing and fix FOSC

5.9.1 Put desiccant into FOSC.

5.9.2 Put FOSC cover on base directly.

5.9.3 Install plastic hoop between FOSC cover and base, tighten hoop locking system, which is to be fixed by hoop fixing bolt then.

5.9.4 FOSC installation

① Aerial application: fix metal hoop and transom to the pole. Please refer to Drawing 8

② Wall mounting application: fix the bracket on the wall with bolt. (metal hoop is not required.)

③ Underground application: metal hoop is not required.

5.9.5 See drawing 8

Important issues: 1. Pay attention while installing plastic hoop.

2. The specification of bolt for fixing the bracket is M8.

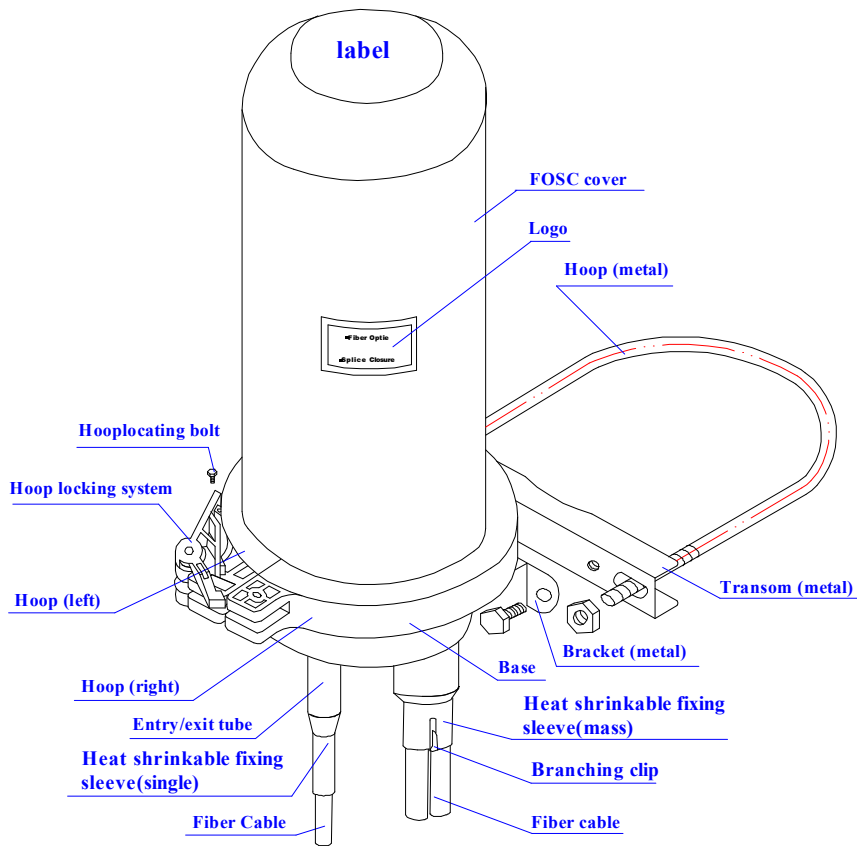

Drawing 8

6. Fiber Optic Splice Closures (FOSC) inspecting and testing items

| Inspecting item | Technical Requirements | Inspecting type | |
|-----------------------------|---|--|-----------------------------------|
| | | Routine test (Before leaving factory) | Type test |
| Package | Each small package contains one fiber optic splice closure, together with its accessories, tools, installation manual and packing list. | full | At least 3 sets sampled each time |
| Appearance | Intact in shape, no burrs, bubbles, chaps, pores, warps, impurities and other defects, all background colors should be even and continual. | | |
| Sign | There is a clear sign on the housing, such as name and model of the product, etc. | | |
| Fiber storage device | The fibers reserved are to be wined in fiber optic splice tray (FOST), the length of fibers housed in FOST is >1.6m, the curved radius is >30mm. During the installation and maintenance, there should be no attenuation on fibers. | At least 3 sets sampled each time | |

| | | | |
|------------------------------------|--|-----------------------------------|------------------------------------|
| Electrical jointing device | Inside FOSC: metallic components of fiber cables has the functions of electrical putting through, earthing connection and disconnecting. It is possible to install earthing deriving device outside the housing | | |
| Sealing performance | After sealing according to the stipulated operation procedures, the injected air pressure is $100\text{KPa} \pm 5\text{Kpa}$, when immersed in clean water of normal temperature for 15 minutes, there should be no air bubbles, then observed for 24 hours, there should be no change of air pressure. | | |
| Re-sealing performance | After reopening and resealing according to the stipulated operation procedures, the injected air pressure is $100\text{KPa} \pm 5\text{Kpa}$, when immersed in clean water of normal temperature for 15 minutes, there should be no air bubbles, then observed for 24 hours, there should be no change of air pressure. | | |
| Pull | Bearing pull is $\geq 800\text{N}$ at axle orientation, there should be no breakage on the housing. | | |
| Punching | Bearing pressure of $2000\text{N}/10\text{cm}$ for 1 minutes, there should be no breakage on the housing | | |
| Impact | Bearing impact energy of $16\text{N} \cdot \text{m}$, 3 times of impacts there should be not breakage on the housing | | |
| Bending | The spot between the FOSC and seal fitting can bear bending tension of 150N at bending angle of $\pm 45^\circ$ for 10 circles, there should be no breakage on the housing | At least 3 sets sampled each time | At least 3 sets sample d each time |
| Torsion | Bearing torsion $50\text{N} \cdot \text{m}$, 10 circle at torsion angle $\pm 90^\circ$. There should be no breakage on the housing. | | |
| Temperature circle | Injected air pressure of $60\text{KPa} \pm 5\text{KPa}$, the temperature circle ranging from $-40^\circ\text{C} \sim +65^\circ\text{C}$, 10 times of the circular tests (one circular consists of high temperature for 2 hours + indoor temperature for 2 hours + low temperature for 2 hours + indoor temperature for 2 hours) when the pressure declines, the amplitude is $\leq 5\text{Kpa}$, immerse the swatch in clean water of normal temperature for 15 minutes, there should be no air bubbles. | | |
| Voltage resistance strength | After sealing the FOSC according to the stipulated operation procedures, immerse it in clean water of normal temperature in 1.5m depth for 24 hours, there should be no breakdown or arc over between the metallic components of the FOSC, between metallic components and the ground at DC 15KV for 1 minutes. | | |
| Isolating resistance | After sealing the FOSC according to stipulated operation procedure, immerse it in clean water in 1.5m depth for 24h, the isolating resistance between the metallic components of the FOSC, between the metallic components and the ground should be $\geq 2 \times 10^4 \text{M}\Omega$. | | |